



UNIVERSITY COLLEGE TATI (UC TATI)

FINAL EXAMINATION QUESTION BOOKLET

COURSE CODE	: BMT 1013
COURSE	: CIRCUIT THEORY
SEMESTER/SESSION	: 2-2023/2024
DURATION	: 3 HOURS

Instructions:

1. This booklet contains 4 questions. Answer **ALL** questions.
2. All answers should be written in answer booklet.
3. Write legibly and draw sketches wherever required.
4. If in doubt, raise your hands and ask the invigilator.

DO NOT OPEN THIS BOOKLET UNTIL YOU ARE TOLD TO DO SO

THIS BOOKLET CONTAINS 7 PRINTED PAGES INCLUDING COVER PAGE

QUESTION 1

- a) Describe the concept of the following terms:
- i. Superposition Theorem (4 marks)
 - ii. Source Transformation (4 marks)
- b) Determine the voltage across R_2 for the circuit in Figure 1 by using superposition theorem. (7 marks)

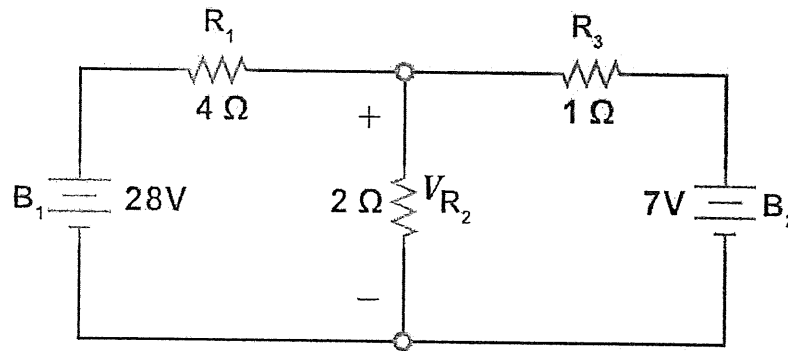

Figure 1

- c) Referring to the circuit in Figure 2,
- i. Explain the steps to apply Source Transformation in a circuit. (6 marks)
 - ii. Analyze the voltage across resistor, V_o . (8 marks)

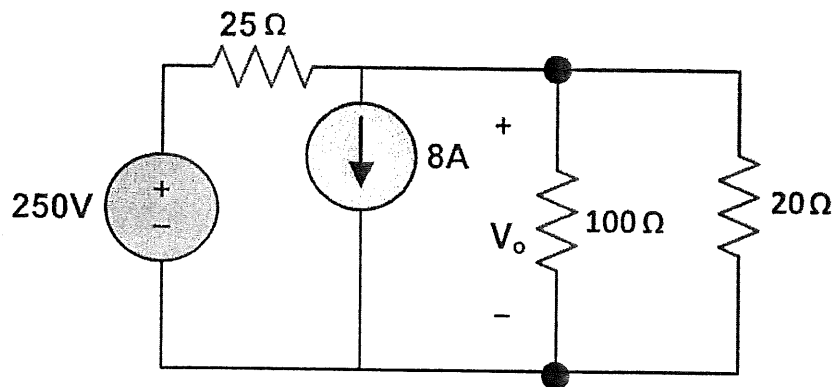

Figure 2

QUESTION 2

- a) Describe the steps to analyze alternating current (AC) circuits. (3 marks)
- b) Given a sinusoid $v(t) = 32 \sin(100t) V$, identify its phasor domain. (3 marks)
- c) Referring to the circuit in Figure 3,
- Describe the steps to find current, i_3 by applying mesh analysis. (8 marks)
 - Analyze the current, i_3 by using mesh analysis. (15 marks)

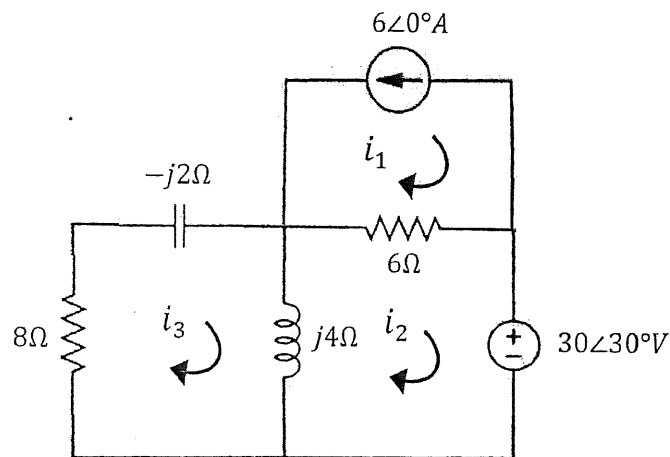

Figure 3

QUESTION 3

- a) State two (2) phasor relationship of voltage and current for each following terms,
- Resistor, R (2 marks)
 - Capacitor, C (2 marks)
 - Inductor, L (2 marks)
- b) Referring to the circuit in Figure 4,
- Determine the input impedance, Z_{in} at $\omega = 10 \text{ rad/s}$. (10 marks)
 - Determine the input admittance Y_{in} . (2 marks)

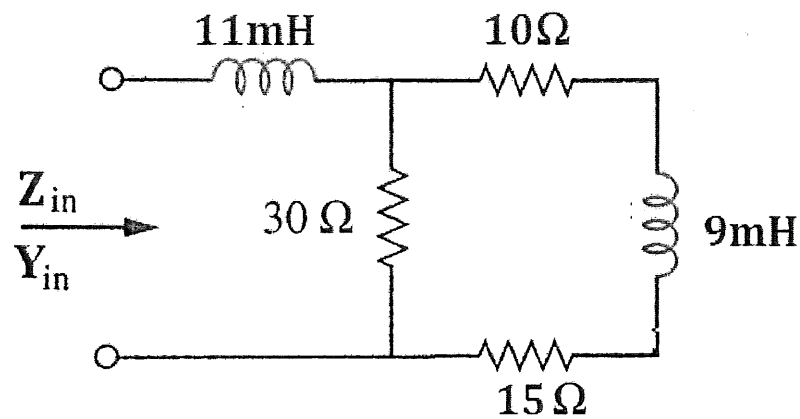

Figure 4

c) For the circuit in Figure 5, analyze:

- i. Voltage, $v(t)$ (4 marks)
- ii. Current, $i(t)$ (6 marks)

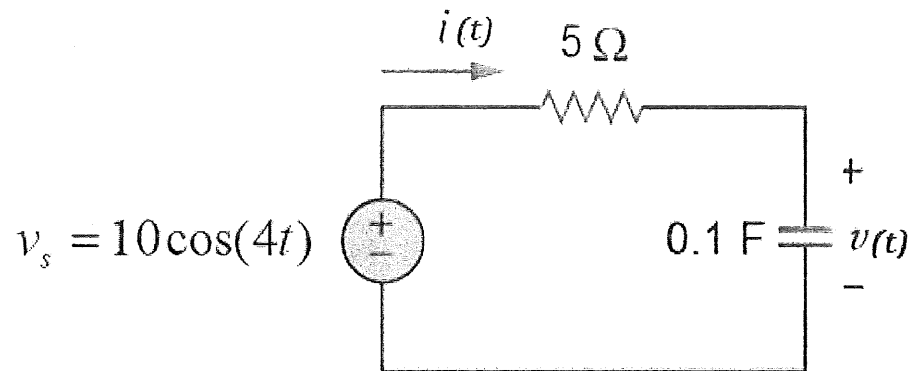

Figure 5

QUESTION 4

a) Answer the following questions:

- i. Describe the series and parallel resonance circuit. (4 marks)
- ii. Illustrate the series and parallel resonance circuit. (4 marks)

b) Referring to the circuit in Figure 6, calculate:

- i. The resonant frequency, f_r . (1 mark)
- ii. The quality factor, Q . (2 marks)
- iii. The bandwidth, BW . (1 mark)
- iv. The upper $-3dB$ frequency points, f_H . (1 mark)
- v. The lower $-3dB$ frequency points, f_L . (1 mark)

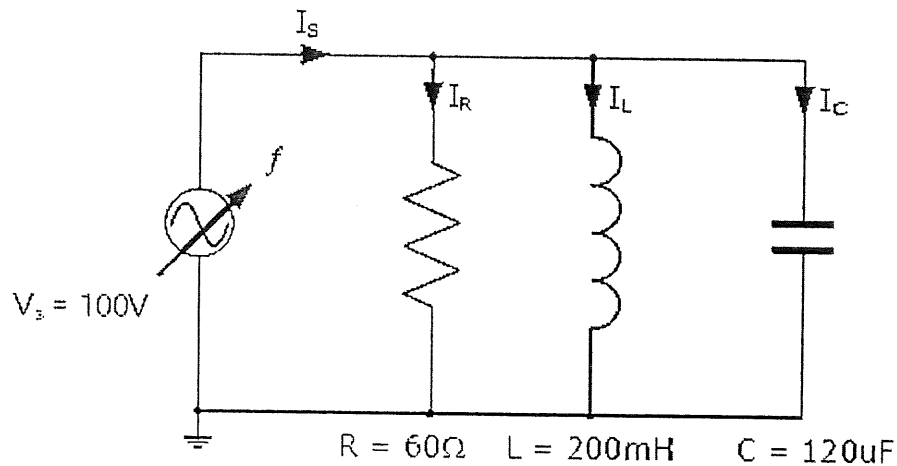

Figure 6

-----End of question-----

CIRCUIT THEORY (BMT 1013)

TABLE OF FORMULAS

AC Circuit				
$v(t) = V_m \cos(\omega t + \varphi)$		$V = V_m \angle \varphi$	$Z = R$	$V = IR$
$i(t) = I_m \cos(\omega t + \varphi)$		$I = I_m \angle \varphi$	$Z = \frac{1}{j\omega C}$	$V = \frac{I}{j\omega C}$
$\omega = 2\pi f$	$z = x + jy$	$z = r \angle \varphi$	$Z = j\omega L$	$V = j\omega L I$
$-\sin(A) = \cos(A + 90^\circ)$		$\sin(A) = \cos(A - 90^\circ)$		$Y = \frac{1}{Z_{in}}$
$-r \angle \varphi = r \cos(\omega t + \varphi \pm 180)$				
Resonant Circuit				
$f_r = \frac{1}{2\pi\sqrt{LC}}$	$V_L = V_C$	$X_L = X_C$	$X_L = 2\pi f L$	$X_C = \frac{1}{2\pi f C}$
$BW = \frac{f_r}{Q}$	$f_H = f_r + \frac{1}{2} BW$		$f_L = f_r - \frac{1}{2} BW$	
Series	$I_m = \frac{V}{R}$	$Q = \frac{X_L}{R}$	$Q = \frac{X_C}{R}$	
Parallel	$I_T = \frac{V}{R}$	$Q = \frac{R}{X_L}$	$Q = \frac{R}{X_C}$	$I_{MAG} = Q \times I_T$

